



RUGGED.

DOCKING STATIONS AND VEHICLE MOUNTS

Chevrolet G-Series Van (2001-2008) Ford E-Series Van (1995-2005)

Placement	Seat Configurations	Drilling Required	Pole	Height Adjustability	Weight	Height	Width	Depth
Passenger side inner front and back seat studs	Bucket	No - attaches seat studs: <i>Chevrolet G-Series Van (1995-2005)</i> <i>Ford E-Series Van (2006-2008)</i>	<i>Upper Pole</i> ordered separately <i>(Lower Tube</i> included with base)	Yes - overall 19.13" to 24.13" (depending on <i>Upper Pole</i> selected)	10.5 lbs	18.88"	17.5"	9.69"

Features

- Heavy gauge steel construction for long-term durability
- Black powdercoat finish for maximum corrosion resistance
- Won't interfere with passenger leg space
- For extra stability a *Support Brace* (Item No. LAC-02 or LAC-03) is recommended

Item No. DS-128P

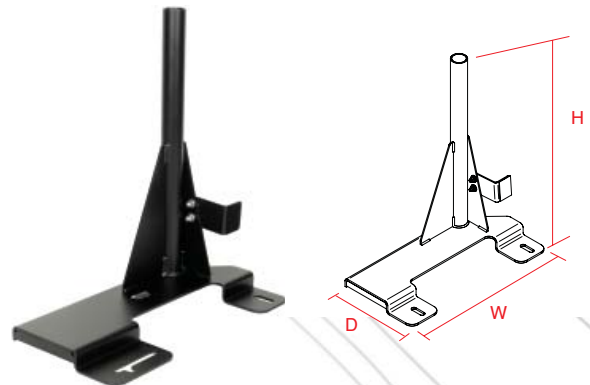

**GAMBER
JOHNSON**[®]
Very Well Connected™

3001 Borham Ave
Stevens Point, WI 54481
Phone: 800-456-6868
Fax: 715-344-8845

Email: gamberj@gamberjohnson.com
Website: www.gamberjohnson.com